

Description

The AVQ400-48S12 is a single output DC/DC converter with standard quarter-brick outline and pin configuration. It delivers up to 33A output current with 12V output voltage. Above 94% ultra-high efficiency and excellent thermal performance make it an ideal choice to supply power in telecom and datacom application. It can work under -40°C ~ +85°C.



Operational Features

- Up to 33A output current
- Ultra-high efficiency 93% type at full load
- Wide input range: 36V ~ 75V
- Excellent thermal performance
- No minimum load requirement
- Basic isolation
- High power density
- Low output noise
- Improved thermal performance
- RoHS 6 compliant

Control Features

- Remote control function (negative or positive logic optional)
- Remote output sense

Protection Features

- Input under voltage lockout
- Output over current protection
- Output over voltage protection
- Over temperature protection

Mechanical Features

- Industry standard quarter-brick pin-out outline
- With baseplate
- Pin length option: 3.8mm, 4.8mm, 5.8mm

Safety & EMC

- Meets basic insulation requirements of IEC/EN/UL/CSA 60950
- UL/CSA 60950 recognized and certified to IEC/EN 60950
- Meets the Low Voltage directives 2006/95/EEC with the Amendment Directive 93/68/EEC which facilitates CE marking in user's end product
- Approved by UL and TUV
- Materials meet UL94,V-0 flammability rating
- Meets conducted emission's requirements of FCC Class B and EN55022 Class B with external filter

Electrical Characteristics

Full operating ambient temperature range is -40°C to +85°C.

Specifications are subject to change without notice.

Parameter		Min.	Typ.	Max.	Unit	Notes & Conditions
Absolute max. ratings						
Input voltage	Non-operating			100	V	100ms
	Operating			80	V	Continuous
Operating temperature		-40		85	°C	
Storage temperature		-55		125	°C	
Voltage at remote ON/OFF pin		-0.3		12	V	
Input characteristics						
Operating input voltage range		36	48	75	V	
Input under-voltage lockout	Turn-on voltage threshold		35	36	V	
	Turn-off voltage threshold	32	34		V	
	Lockout voltage hysteresis	1		3	V	
Max. input current				13	A	36V _{in} , full load
No-load input current				0.2	A	
Standby Input current			0.01	0.1	A	Remote OFF
Inrush current transient rating				1	A ² s	See Figure 14
Input reflected ripple current				150	mA	Through 12μH inductor; see Figure 14
Recommended input fuse				15	A	External fast blow fuse recommended; see Figure 11
Input filter component values (C/L)			8.8\0.68		μF\μH	Internal values
Recommended external input capacitance			100		μF	Low ESR capacitor recommended; see Figure 11
Output characteristics						
Output voltage set point (standard option)		11.80	12	12.20	V	48V _{in} , full load
Output voltage line regulation				0.2	%	
				24	mV	

Parameter		Min.	Typ.	Max.	Unit	Notes & Conditions
Output voltage load regulation				0.5	%	
				60	mV	
Output voltage temperature regulation				0.02	%/°C	
Total output voltage range		11.8	12	12.2	V	Over sample, line, load, temperature & life
Output voltage ripple and noise				150	mVpp	See Figure 2 20MHz bandwidth; see Figure 14
Operating output current range		0		33	A	
Output DC current-limit inception		34.65		42.9	A	Hiccup: auto-restart when over-current condition is removed
Output DC current-limit shutdown voltage					V	
Output capacitance		470	1000	10000	μF	High frequency and low ESR is recommended
Dynamic characteristics						
Dynamic response	50% ~ 75% ~ 50% $I_{o,max}$, 0.1A/μs			600	mV	See Figure 4 Test condition: 25°C, nominal input voltage, see Figure 11
	Setting time			700	μs	Recovery to within 1% $V_{o,nom}$
	50% ~ 75% ~ 50% $I_{o,max}$, 1A/μs			1200	mV	See Figure 5 Test condition: 25°C, nominal input voltage, see Figure 11
	Setting time			700	μs	Recovery to within 1% $V_{o,nom}$
Turn-on transient	Rise time			100	ms	Full load, see Figure 6
	Turn-on delay time			150	ms	
	Output voltage overshoot			5	% V_o	
Efficiency						
100% load		92.5	93		%	See Figure 1
50% load		94	95		%	See Figure 1

Electrical Characteristics (Continued)

Parameter		Min.	Typ.	Max.	Unit	Notes & Conditions
Isolation characteristics						
Isolation voltage (conditions: 1mA for 60s, slew rate of 1500V/10s)		1500			V	Basic insulation, pollution degree 2, input to output
		1500			V	Basic insulation, pollution degree 2, input to baseplate
		500			V	Functional insulation, pollution degree 2, output to baseplate
Feature characteristics						
Switching frequency		130	140	150	kHz	
Remote ON/OFF control (positive logic)	Off-state voltage	-0.7		1.2	V	See Figure 8 and Figure 9
	On-state voltage	3.5		12	V	
Remote ON/OFF control (negative logic)	Off-state voltage	3.5		12	V	
	On-state voltage	-0.7		1.2	V	
Output over-voltage protection		13		16	V	Hiccup: auto-restart when over-voltage condition is removed
Over-temperature shutdown			125		°C	See Figure 16. Tested under thermal balance condition
Over-temperature hysteresis			5		°C	
Reliability characteristics						
Calculated MTBF (telcordia)			1.5		10 ⁶ h	Telcordia SR-332-2006; 80% load, 300LFM, 40°C T _a

Electromagnetic compatibility requirements

Test Item	Regulations	Criteria	Notes & Conditions
Conducted Emission	EN 55022 DC input port, Class B Limits		See <i>EMC Test Conditions</i>
Immunity to electrostatic discharge	IEC/EN61000-4-2 Enclosure port, Level 3	B	
Immunity to electrical fast transient	IEC/EN61000-4-4 DC input port, Level 3	B	
Immunity to surges	IEC/EN61000-4-5 DC input port Line to Ground (earth): 600V Line to Line: 600V	B	
Immunity to continuous conducted interference	IEC/EN61000-4-6 DC input port, Level 2	A	
Immunity to voltage dips and short interruptions and voltage variations	EN 61000-4-29 DC input port	B	

Criterion A: Normal performance during and after test.

Criterion B: For EFT and surges, low-voltage protection or reset is not allowed. Temporary output voltage fluctuation ceases after disturbances ceases, and from which the EUT recovers its normal performance automatically.

For Dips and ESD, output voltage fluctuation or reset is allowed during the test, but recovers to its normal performance automatically after the disturbance ceases.

Criterion C: Temporary loss of output, the correction of which requires operator intervention.

Criterion D: Loss of output which is not recoverable, owing to damage to hardware.

Qualification Testing

Parameter	Unit (pcs)	Test condition
Halt test	4 ~ 5	$T_{a,min} - 10^{\circ}\text{C}$ to $T_{a,max} + 10^{\circ}\text{C}$, 5°C step, V_{in} = min to max, 0 ~ 105% load
Vibration	3	Frequency range: 5Hz ~ 20Hz, 20Hz ~ 200Hz, A.S.D: $1.0\text{m}^2/\text{s}^3$, -3db/oct, axes of vibration: X/Y/Z Time: 30min/axis
Mechanical shock	3	30g, 6ms, 3axes, 6directions, 3time/direction
Thermal shock	3	-40°C to 100°C , unit temperature 20 cycles
Thermal cycling	3	-40°C to 55°C , temperature change rate: $1^{\circ}\text{C}/\text{min}$, cycle: 2 cycles
Humidity	3	40°C , 95%RH, 48h
Solder ability	15	IPC J-STD-002C-2007

Characteristic Curves

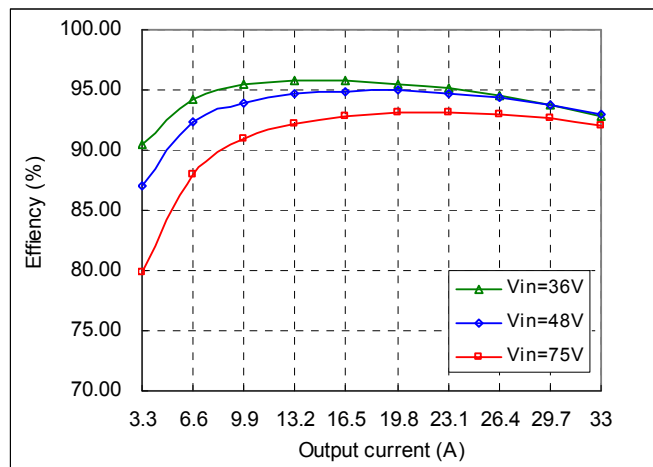

Figure 1 Efficiency and output current, $T_a = 25^{\circ}\text{C}$, 400LFM, $V_o = 12\text{V}$

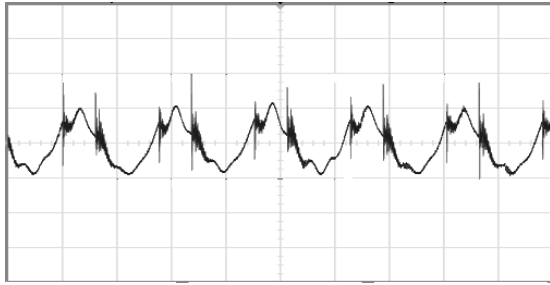

Figure 2 Output ripple & noise (2 μ s/div, 16mV/div), see Figure 14 for test configuration

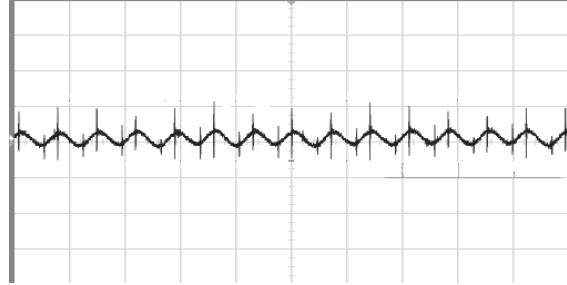

Figure 3 Input reflected ripple current (5 μ s/div, 20mA/div), see Figure 14 for test configuration

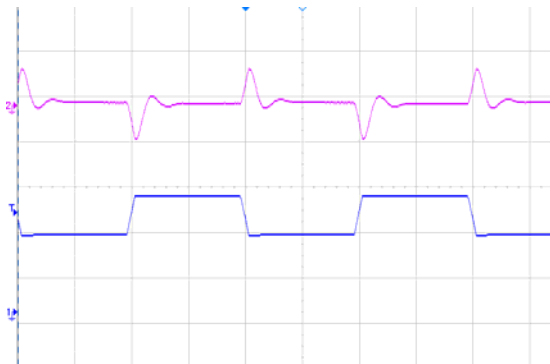

Figure 4 Dynamic response for 25% load step (50% ~ 75% ~ 50%) and 0.1A/ μ s slew rate, (500 μ s/div), see Figure 11 for test configuration; CH2-output voltage (500mV/div); CH1-output current (10A/div)

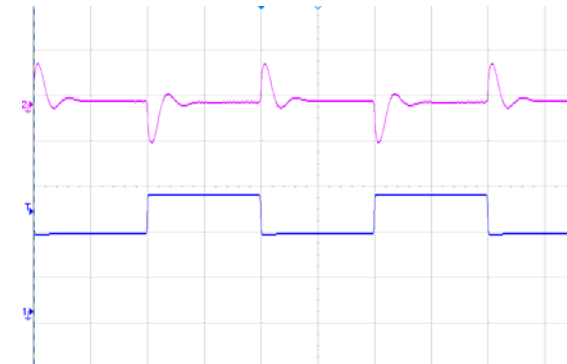

Figure 5 Dynamic response for 25% load step (50% ~ 75% ~ 50%) and 1A/ μ s slew rate, (500 μ s/div), see Figure 11 for test configuration; CH2-output voltage (500mV/div); CH1-output current (10A/div)

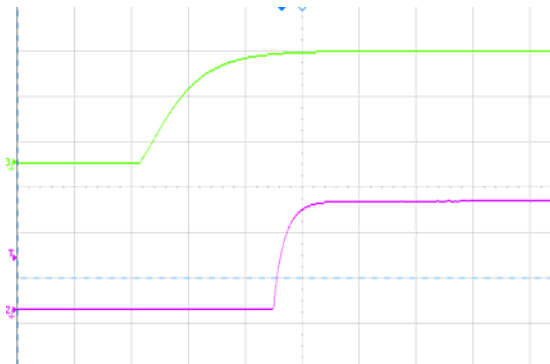

Figure 6 Output voltage startup by power on, (50ms/div), see Figure 11 for test configuration; CH2-output voltage (5V/div); CH3-input voltage (20V/div)

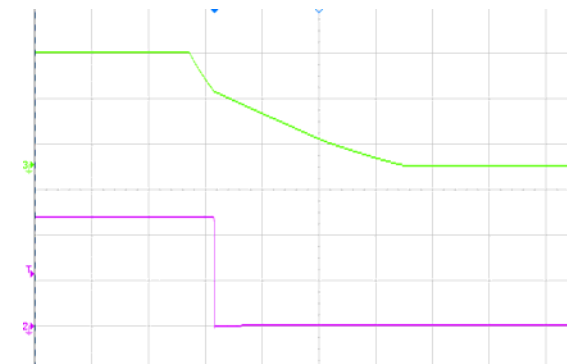

Figure 7 Output voltage shut down by power off, (100ms/div), see Figure 11 for test configuration; CH2-output voltage (5V/div); CH3-input voltage (20V/div)

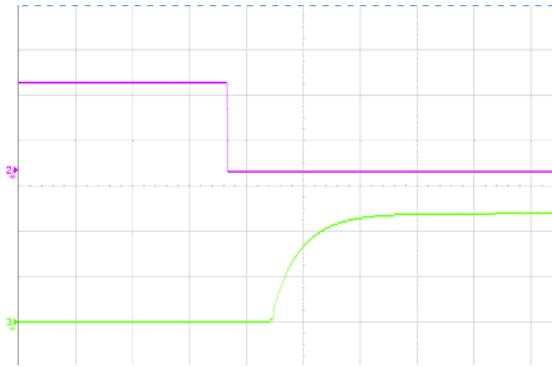

Figure 8 Output voltage startup by remote ON, (20ms/div), see Figure 11 for test configuration; CH3-output voltage (5V/div); CH2-remote ON voltage (2V/div)

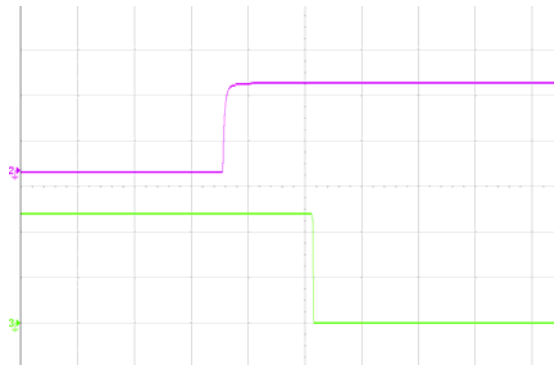

Figure 9 Output voltage shutdown by remote OFF, (10ms/div), see Figure 11 for test configuration; CH3-output voltage (5V/div); CH2-remote OFF voltage (2V/div)

Application Note

Typical Application

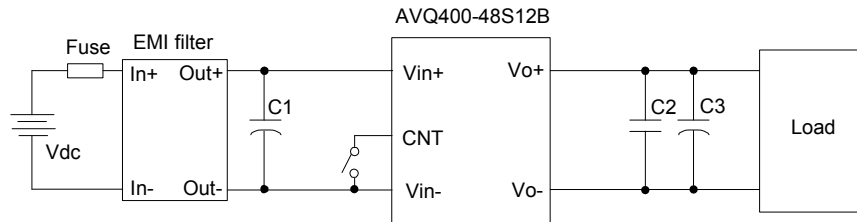

Figure 11 Typical application

C1: 100 μ F/100V electrolytic capacitor; P/N: UPW2A101MHD (Nichicon) or equivalent caps
 C2: 1 μ F/100V X7R ceramic capacitor; P/N: C3225X7R2A105KT0L0U (TDK) or equivalent caps
 C3: 1000 μ F/25V electrolytic capacitor; P/N: UPM1H102MHD (Nichicon) or equivalent caps
 Fuse: External fast blow fuse with a rating of 15A. The recommended fuse model is 21612.5P from LITTLEFUSE.

Remote ON/OFF

Either positive or negative remote ON/OFF logic is available in AVQ400-48S12B. The logic is CMOS and TTL compatible.

Figure 12 is the detailed internal circuit and reference in AVQ400-48S12B.

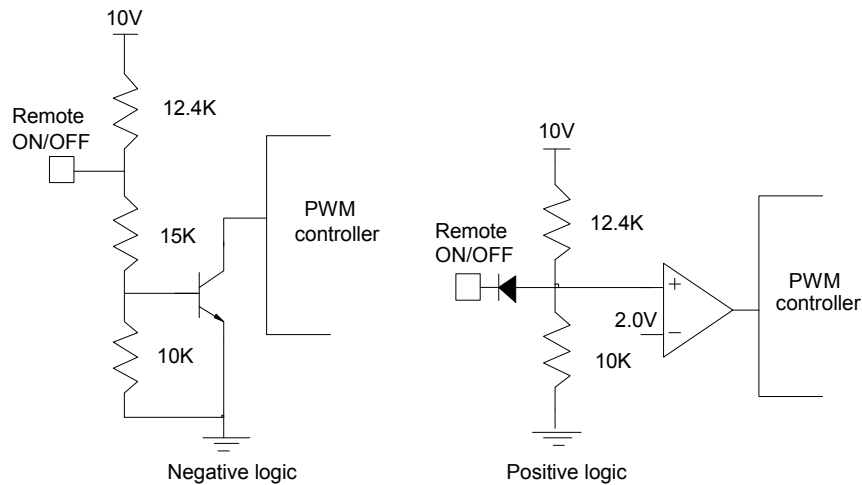

Figure 12 Remote ON/OFF internal diagram

The voltage between pin Remote ON/OFF and pin Vin- must not exceed the range listed in table “Feature characteristics” to ensure proper operation. The external remote ON/OFF circuit is highly recommended as shown in Figure 13.

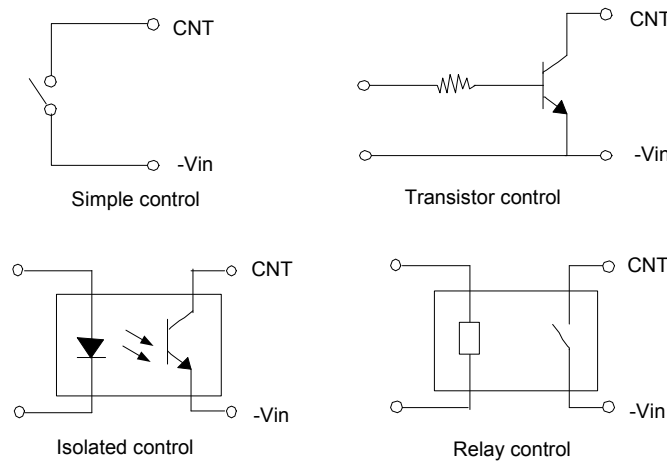

Figure 13 External remote ON/OFF circuit

Input Ripple & Inrush Current And Output Ripple & Noise Test Configuration

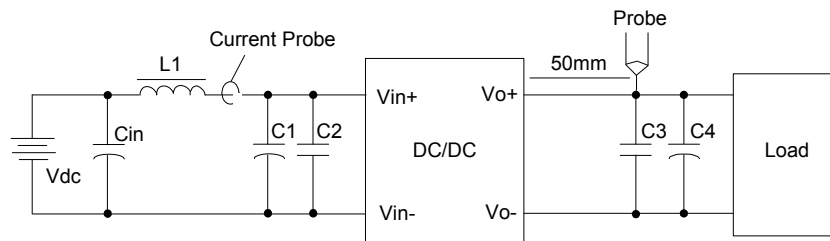

Figure 14 Input ripple & inrush current, output ripple & noise test configuration

Vdc: DC power supply

L1: 12μH

Cin: 220μF/100V typical

C1: 100μF/100V electrolytic capacitor; P/N: UPW2A101MHD (Nichicon) or equivalent caps

C2~C3: 1μF/100V X7R ceramic capacitor; P/N: C3225X7R2A105KT0L0U (TDK) or equivalent caps

C4: 1000μF/25V electrolytic capacitor; P/N: UPM1H102MHD (Nichicon) or equivalent caps

Note: It is recommended to use a coaxial cable with series 50Ω resistor and 0.68μF ceramic capacitor or a ground ring of probe to test output ripple & noise.

EMC Test Conditions

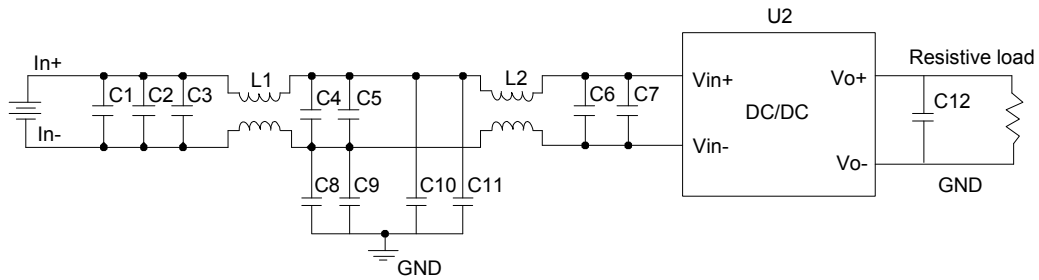

Figure 15 EMC test configuration

C1~C5: SMD ceramic capacitor-100V-1000nF-X7R-1210

C6: SMD ceramic capacitor-100V-100nF-±10%-X7R-1206

L1, L2: Common mode inductor-single phase-473μh-±25%-14A magnetic ring 1×25.4×12.7mm-working temperature range includes module temperature rise. Temperature rise at rated current: 55°C (max.)

C8~C11: High-voltage CHIP ceramic capacitor. Capacitance: 0.22U/630V/X7R. Size: 2220. Capable of withstanding 1kV voltage

C7: Input electrolytic capacitor, according to the same type as C1 in Figure 11

C12: Output electrolytic capacitor, according to the same type as C3 in Figure 11

U2: Module to test, AVQ400-48S12

Thermal Considerations

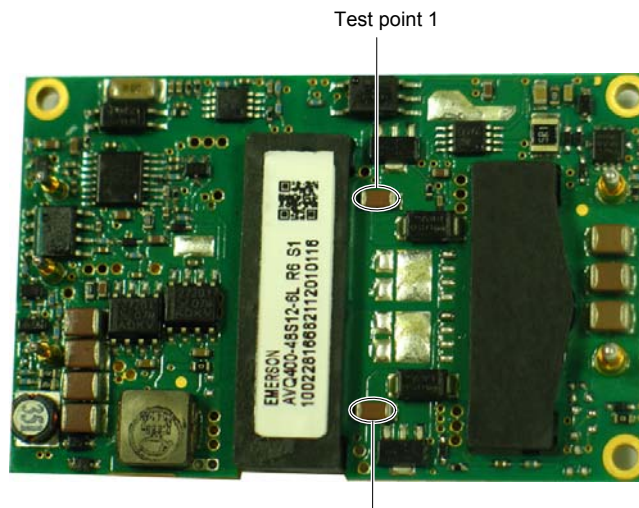

Temperature test points on FR-4 board

Figure 16 Temperature test points

Table 1 Temperature limit of the test points

Test Point	Temperature limit
Test point 1	118°C
Test point 2	118°C

Figure 17 shows the derating output current vs. ambient air temperature at different air velocity.



Figure 17 Output power derating, 48V_{in}, air flowing across the converter from pin 1 to pin 3

Mechanical Diagram

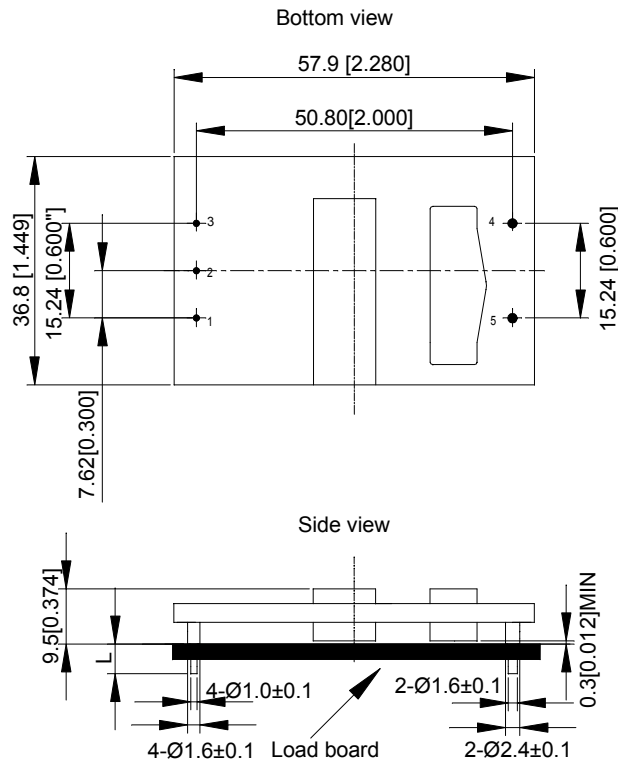

Unit: mm[inch] Bottom view: pin on upside
 Tolerance: X.Xmm±0.5mm[X.X in.±0.02in.]
 X.XXmm±0.25mm[X.XX in.±0.01in.]

Figure 18 Mechanical diagram

Pin length option

Device code suffix	L
-4	4.8mm ± 0.25 mm
-6	3.8mm ± 0.25 mm
-8	2.8mm ± 0.25 mm
None	5.8mm ± 0.25 mm

Pin Designations

Pin NO.	Name	Function
1	V_{in+}	Positive input voltage
2	Remote ON/OFF	Remote control
3	V_{in-}	Negative input voltage
4	V_{o-}	Negative output voltage
5	V_{o+}	Positive output voltage

Soldering

The product is intended for standard manual or wave soldering.

When wave soldering is used, the temperature on pins is specified to maximum 255°C for maximum 7s.

When soldering by hand, the iron temperature should be maintained at 300°C ~ 380°C and applied to the converter pins for less than 10s. Longer exposure can cause internal damage to the converter.

Cleaning of solder joint can be performed with cleaning solvent IPA or simulative.

The product is intended for standard manual or wave soldering.

When wave soldering is used, the temperature on pins is specified to maximum 260°C for maximum 7s.

When soldering by hand, the iron temperature should be maintained at 300°C ~ 380°C and applied to the converter pins for less than 10s. Longer exposure can cause internal damage to the converter.

Cleaning of solder joint can be performed with cleaning solvent IPA or simulative.

Assembly

The maximum length of the screw driven into heatsink is 1.0mm.

Ordering Information

AVQ400	-	48	S	12		B	-	4	L
□		□	□	□	□	□		□	□

□	Model series	AVQ: high efficiency quarter brick series, 400: output power 400W
□	Input voltage	48: 36V ~ 75V input range, rated input voltage 48V
□	Output number	S: single output
□	Rated output voltage	12: 12V output
□	Remote ON/OFF logic	Default: negative; P: positive logic
□	Baseplated	With baseplate
□	Pin length	-4: 4.8mm ± 0.25mm
□	RoHS status	L: RoHS, R6; Y: RoHS, R5

Model number	Description
AVQ400-48S12-6L	3.8mm pin length; negative on logic; without thread inside mounting hole; R6 compliant

Hazardous Substances Announcement (RoHS Of China)

Parts	Hazardous substances					
	Pb	Hg	Cd	Cr ⁶⁺	PBB	PBDE
AVQ400-48S12B	x	x	x	x	x	x

x: Means the content of the hazardous substances in all the average quality materials of the part is within the limits specified in SJ/T-11363-2006

√: Means the content of the hazardous substances in at least one of the average quality materials of the part is outside the limits specified in SJ/T11363-2006

Emerson Network Power Co., Ltd. has been committed to the design and manufacturing of environment-friendly products. It will reduce and eventually eliminate the hazardous substances in the products through unremitting efforts in research. However, limited by the current technical level, the following parts still contain hazardous substances due to the lack of reliable substitute or mature solution:

1. Solders (including high-temperature solder in parts) contain plumbum.
2. Glass of electric parts contains plumbum.
3. Copper alloy of pins contains plumbum